

PRODUCT DATA

9 09 67 23 **Resinous
Flooring**

UCRETE® WR

Polyurethane concrete for forming
cove bases and renovating walls

Description

Ucrete® WR is a four-component polyurethane-concrete material. It is used with other Ucrete® products to form cove bases. Ucrete® WR applies by trowel and yields excellent results; it can be installed to a depth of 1/8" (3 mm) in a single lift or to greater thicknesses in multiple lifts. It is extremely tough and has many physical properties that exceed those of typical concrete.

Yield

For coverage rates refer to the Ucrete® Contractor Installation Guideline.

Packaging

Part 1: 1 qt (0.95 L) cans

Part 2: 1 qt (0.95 L) cans

Part 3: 24 lb (10.7 kg) bag

Part 4: 1 lb (0.4 kg) pigment packs

Colors

Red, gray, cream, green, black, blue and charcoal.

Because Ucrete® WR is a colored polyurethane concrete, color uniformity cannot be completely guaranteed from batch to batch. Do not mix batches within a single area.

Shelf Life

Part 1:

6 months when properly stored

Parts 2 and 3:

1 year when properly store

Part 4:

2 years when properly stored.

Features

- Fast curing
- Unaffected by freeze-thaw cycles
- Solvent free
- 30 years of project references
- Excellent impact and abrasion resistance
- Wide temperature service range from -50 to 235° F (-45 to 113° C)
- Can be applied to 7 – 10 day old concrete
- Chemical resistant
- Extremely high bond strength
- Coefficient of thermal expansion similar to concrete

Benefits

- Minimizes down time
- For interior or exterior use
- Low odor; VOC compliant
- Proven track record
- Handles heavy traffic
- Exceeds that of typical epoxy overlays
- Accelerates work schedules
- Tolerates organic and inorganic acids, alkalis, and salts
- Reduces shear at bond line
- Prevents shear at bondline

Storage

Store and transport in unopened containers in a clean, dry area at stable temperatures approximating 65° F (18° C).

Where to Use

APPLICATION

- To protect drains, tank bases, sumps, containment pits, curbs, and other vertical surfaces
- Where severe conditions exist—high impact pressure, thermal shock, and chemical exposure
- Use with all Ucrete® flooring products
- Chemical processing facilities
- Meat, poultry, and dairy plants
- Bakeries
- Confectionery-packaging areas

- Food warehouses
- Textile-production sites
- Precious-metal refineries
- Pharmaceutical facilities
- Freezers and refrigerated storage areas

LOCATION

- Interior and exterior applications

SUBSTRATE

- New and aged concrete; when applying over other surfaces, contact BASF Technical Service

Technical Data

Composition

Ucrete® WR is a four-component polyurethane-concrete cove-base material.

Compliances

- USDA accepted for use in federally inspected meat and poultry plants in the USA
- Ministry of Agriculture, Canada, accepted for use in food establishments in Canada
- British Standard Specifications (BSS), for use in the U.K.

Test Data

| PROPERTY | RESULTS | TEST METHODS |
|---|---|--------------|
| Compressive strength , psi (MPa) | 7,000 (48.3) | ASTM C 579 |
| Tensile strength , psi (MPa) | 1,000 (5.5) | ASTM C 307 |
| Coefficient of thermal expansion , in/in/° F (cm/cm/° C) | 1.1 x 10 ⁻⁵ (2.0 x 10 ⁻⁵) | ASTM C 531 |
| Density , lb/ft ³ (g/cm ³) | 130 (2.8) | ASTM C 905 |
| Resistance to fungi growth | Passes, rating of 1 | ASTM G 21 |
| Impact resistance | No visible damage or deterioration at min.160 in-lb | ASTM D 2794 |
| Compressive modulus , psi (MPa) | 1.7 x 10 ⁵ (1,170) | ASTM C 469 |
| Flexural strength , psi (MPa) | 2,200 (15.2) | ASTM C 580 |
| Modulus of elasticity , psi (MPa) | 1.7 x 10 ⁵ (1,170) | ASTM C 469 |
| Thermal conductivity , BTU-in/in-ft ² °F (W/mK) | 8 (1.2) | ASTM C 177 |
| Water absorption , % | < 0.1 | ASTM C 413 |
| Abrasion resistance , g loss; CS-17 Wheel, 1,000 cycles | 0.07 | ASTM D 4060 |
| Resistance to elevated temperatures | No flow or softening | MIL-D-3134 |
| Adhesion , psi (MPa) | 400 (2.8) Cohesive / adhesive failure | ASTM D 4541 |

Chemical Resistance

In accordance with ASTM D 1308, Ucrete® WR will resist exposure for up to 48 days at 72° F (22° C) for the following chemicals.

- Dilute mineral acids, including hydrochloric (< 35%), phosphoric (< 50%), and sulfuric (< 30%)
- Alkalies, including potassium hydroxide to a 50% concentration
- Some dilute organic acids such as acetic (30%), formic, citric, and uric
- Fats, oils, and sugars
- Mineral oils, diesel fuel, kerosene, and gasoline
- Most organic solvents, including aliphatic and aromatic hydrocarbons and alcohol

NOTE: Full chemical resistance is achieved after curing for 7 days. For chemical resistance to a specific compound, consult the Ucrete® Chemical Resistance Guide for this flooring system. Contact your BASF representative for more information.

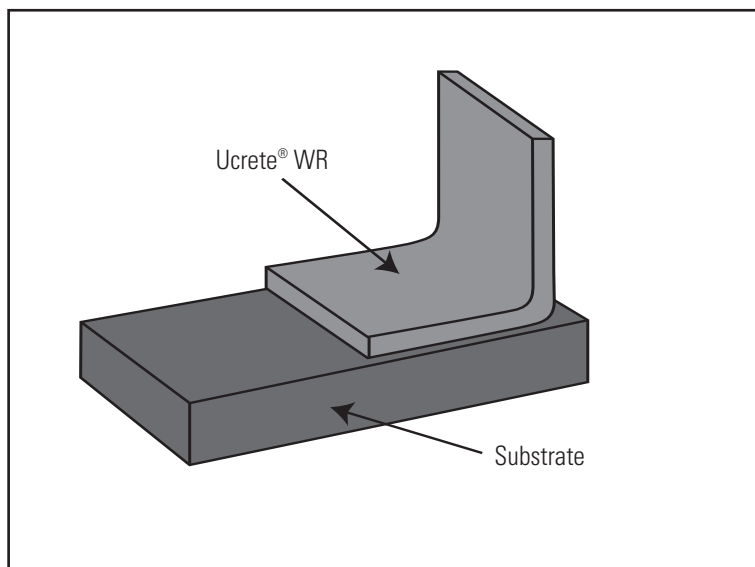

How to Apply

Ucrete® systems are installed by approved contracting firms who have completed the manufacturer's training workshops. Ucrete® is a globally branded product line with industry synergies around the world.

The following is only a summary of the installation techniques used by your Ucrete® approved contractors. Refer to the Ucrete® Contractor Installation Guideline for more information.

Surface Preparation

The success or failure of any application depends on proper preparation of the substrate. Ucrete® recommends a clean, sound substrate free of all surface contaminants. For WR at 1/8", profile to ICRI CSP 3 – 4. For WR at 3/16", profile to ICRI CSP 4–5. For WR at 5/16", profile to CSP 5 – 6.

Application

1. Prime the surface with the appropriate primer. See the Ucrete® Contractor Installation Guideline for details.
2. Mix the 4 components of Ucrete® WR using a mechanical mixer. The materials are supplied in pre-measured containers.
3. Trowel Ucrete® WR at a depth of 1/8" (3 mm) per lift. Use multiple lifts for thicknesses greater than 1/8" (3 mm). See the Ucrete® Contractor Installation Guide for additional information.

Maintenance

Regular cleaning and maintenance will prolong the life of all polymer flooring systems, enhance their appearance, and reduce any tendency to retain dirt. Ucrete® WR will withstand steam-cleaning, high-pressure hot-water washdowns (2,500 psi [17.2 MPa] at 180° F [82° C]) along with a wide range of decontamination and degreasing materials.

For Best Performance

- Substrates must be structurally sound, clean, dry, and free of any foreign matter that could inhibit adhesion.
- Do not apply at temperatures below 40° F (4° C) or above 85° F (29° C) or if the relative humidity is above 85%.
- Do not expose the Ucrete® WR to any chemicals until fully cured (12 – 24 hours at 70° F [21° C]). When temperatures fall below 50° F (10° C), curing time could exceed 48 hours to reach full operational strength.
- Do not apply Ucrete® WR to unreinforced drywall, asphalt or bitumen substrates, glazed tile, nonporous brick or tile, magnesite, copper, aluminum, existing coatings, epoxies, or polyesters.
- The architect and owner should address cove design with the flooring contractor before the job starts.
- BASF representatives and flooring specialists are available to assist you in the selection of the proper flooring system. Call 1-800-243-6739 for in-house and field technical assistance.
- Make certain the most current versions of product data sheet and MSDS are being used; call Customer Service (1-800-433-9517) to verify the most current versions.
- Proper application is the responsibility of the user. Field visits by BASF personnel are for the purpose of making technical recommendations only and not for supervising or providing quality control on the jobsite.

Health, Safety and Environmental

Read, understand and follow Material Safety Data Sheets and product labels for all components of this flooring system prior to use. The MSDS can be obtained by searching for them on www.BuildingSystems.BASF.com, e-mailing your request to basfbscst@basf.com or calling 800/433-9517. Use only as directed.

**BASF Construction Chemicals, LLC –
Building Systems**

889 Valley Park Drive
Shakopee, MN, 55379

www.BuildingSystems.BASF.com

Customer Service 800-433-9517
Technical Service 800-243-6739



LIMITED WARRANTY NOTICE Every reasonable effort is made to apply BASF exacting standards both in the manufacture of our products and in the information which we issue concerning these products and their use. We warrant our products to be of good quality and will replace or, at our election, refund the purchase price of any products proved defective. Satisfactory results depend not only upon quality products, but also upon many factors beyond our control. Therefore, except for such replacement or refund, **BASF MAKES NO WARRANTY OR GUARANTEE, EXPRESS OR IMPLIED, INCLUDING WARRANTIES OF FITNESS FOR A PARTICULAR PURPOSE OR MERCHANTABILITY, RESPECTING ITS PRODUCTS,** and BASF shall have no other liability with respect thereto. Any claim regarding product defect must be received in writing within one (1) year from the date of shipment. No claim will be considered without such written notice or after the specified time interval. User shall determine the suitability of the products for the intended use and assume all risks and liability in connection therewith. Any authorized change in the printed recommendations concerning the use of our products must bear the signature of the BASF Technical Manager.

This information and all further technical advice are based on BASF's present knowledge and experience. However, BASF assumes no liability for providing such information and advice including the extent to which such information and advice may relate to existing third party intellectual property rights, especially patent rights. In particular, BASF disclaims all **CONDITIONS AND WARRANTIES, WHETHER EXPRESS OR IMPLIED, INCLUDING THE IMPLIED WARRANTIES OF FITNESS FOR A PARTICULAR PURPOSE OR MERCHANTABILITY, BASF SHALL NOT BE RESPONSIBLE FOR CONSEQUENTIAL, INDIRECT OR INCIDENTAL DAMAGES (INCLUDING LOSS OF PROFITS) OF ANY KIND.** BASF reserves the right to make any changes according to technological progress or further developments. It is the customer's responsibility and obligation to carefully inspect and test any incoming goods. Performance of the product(s) described herein should be verified by testing and carried out only by qualified experts. It is the sole responsibility of the customer to carry out and arrange for any such testing. Reference to trade names used by other companies is neither a recommendation, nor an endorsement of any product and does not imply that similar products could not be used.

For professional use only. Not for sale to or use by the general public.

Form No. 1025794 9/07

Printed on recycled paper including 10% post-consumer fiber.

© 2007 BASF
Printed in U.S.A.